

	mm
T2	TB + 92 + Z3 - M2
E2	TB - M2
KT2	≥ T2
M2	≥ S + 75 ≤ TB - 390

	mm
S	18 - 26
T2	≥ 344
TB	440 - 750
TH (III 20)	1200 - 2200
TH (III 25)	1900 - 2700
Z1	0 - 6
Z2	0 - 6
Z3	2 - 5
Z4	2 - 5
Z5	2 - 5

Z3	TA3	Z5	TA4
2 mm (3/16")	29 mm (1 1/8")	2 mm (3/16")	22.5 mm (7/8")
3 mm (1/4")	28 mm (1 1/8")	3 mm (1/4")	22 mm (7/8")
4 mm (5/16")	27 mm (1 1/8")	4 mm (5/16")	21.5 mm (7/8")
5 mm (3/8")	26 mm (1 1/8")	5 mm (3/8")	21 mm (7/8")

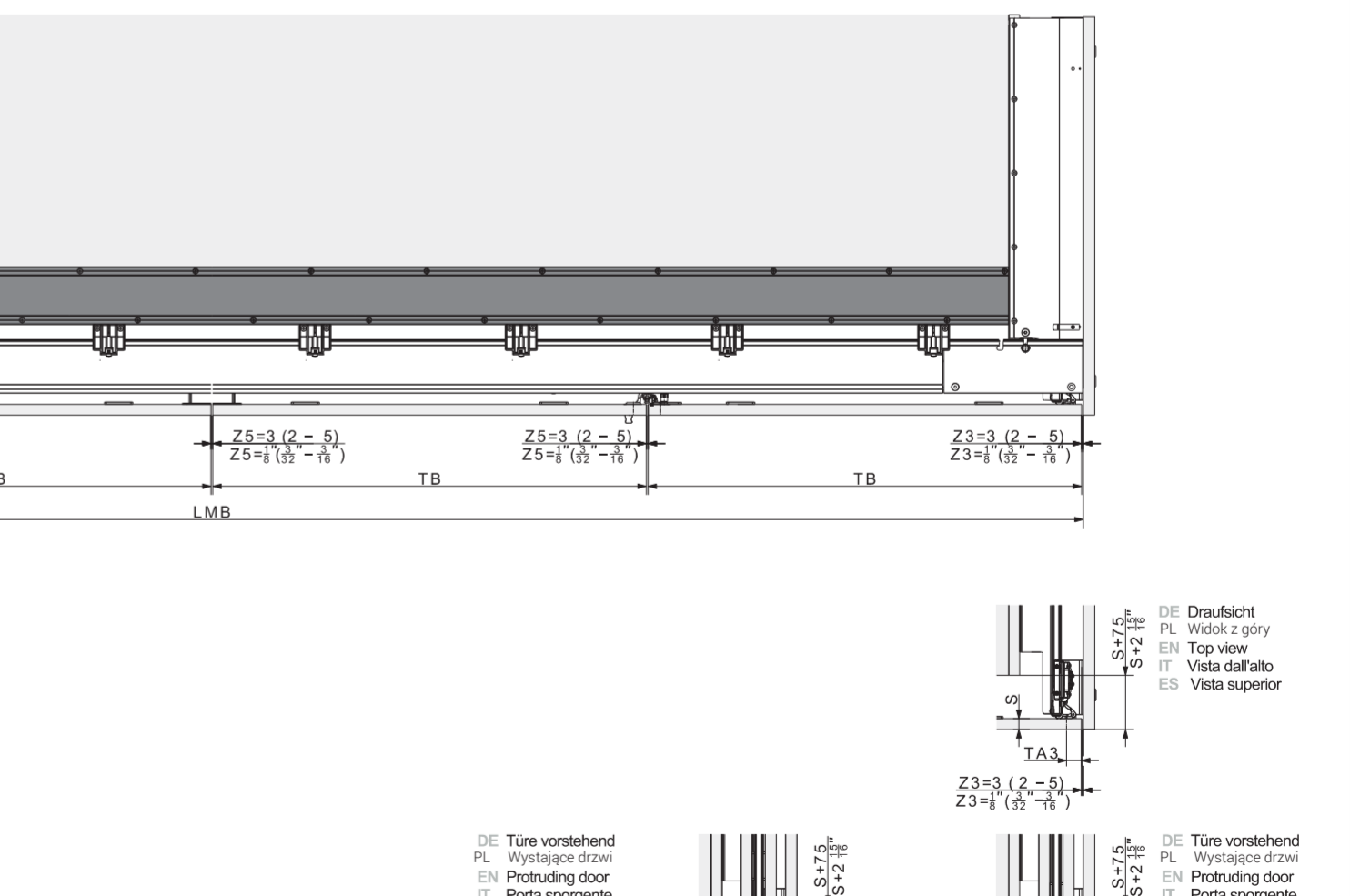
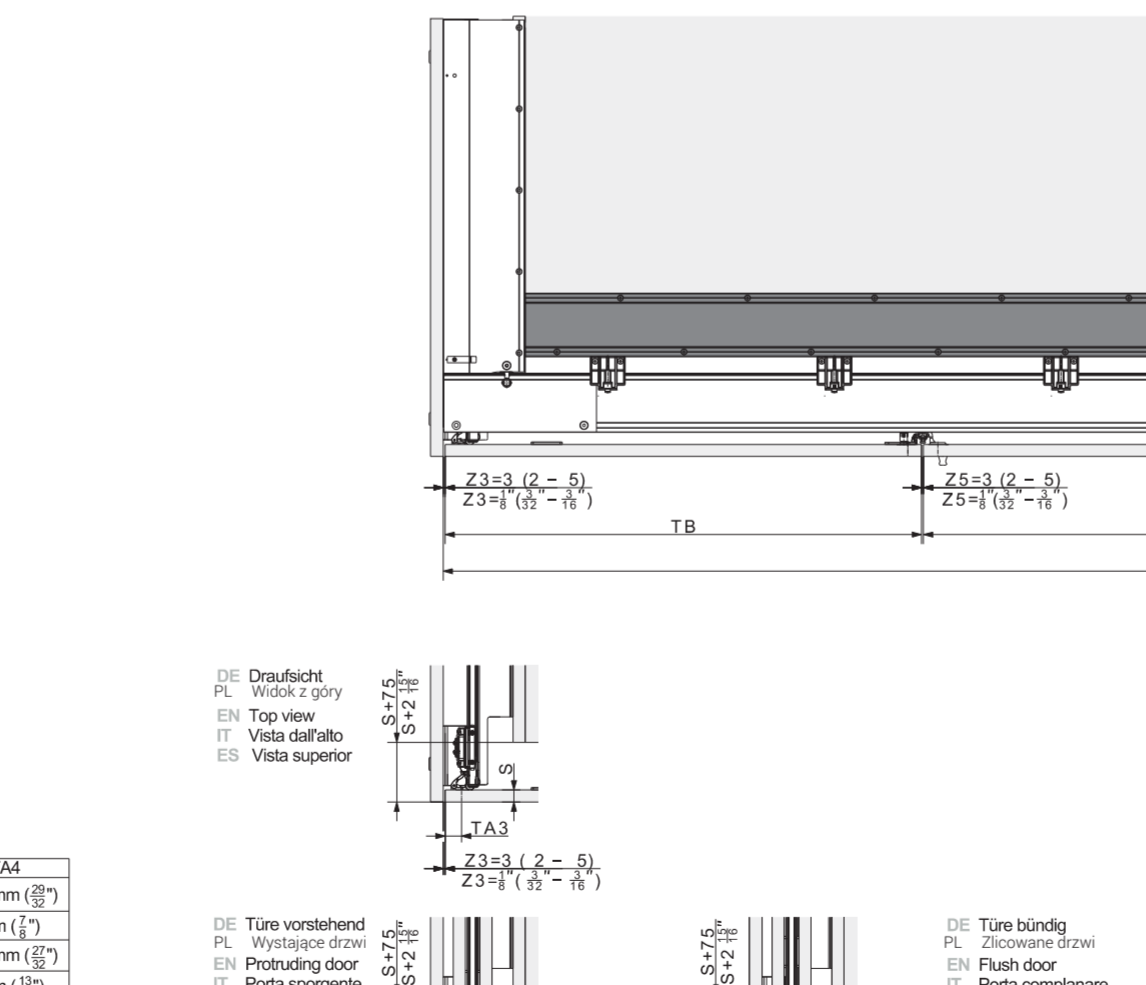

DE Abkürzungen / PL Legenda / EN Abbreviations / IT Abbreviazioni / ES Abreviaturas

DE	PL	EN	IT	ES
E2	Głębokość wsunęcia	Slide-in depth	Profondità di inserimento	Profundidad de introducción
EH	Wysokość montażu	Installation height	Altezza d'incasso	Altura de montaje
KT2	Głębokość korpusu	Cabinet depth	Profondità mobile	Profundidad del mueble
LMB	Szerokość w świetle zabudowy	Inside clearance	Larghezza luce	Ancho interior
M2	Trzpień nad korpusem	Door projection over cabinet	Sporgenza anta sopra il mobile	Solape de la puerta sobre el cuerpo
S	Grubość drzwi	Door thickness	Spessore anta	Grosor de la puerta
T2	Głębokość montażowa	Hardware depth	Profondità ferramenta	Profundidad del herraje
TA	Odległość od środka puszek	Axis-centre distance of conoaled hinge	Distanza scatola asse	Distanza de la cazoleta
TB	Szerokość drzwi	Door width	Larghezza anta	Ancho de puerta
TH	Wysokość drzwi	Door height	Altezza anta	Altura de puerta
Z	Luftzwischenraum	Air gap	Traferro d'aria	Espacio libre

# Hawa Folding Concepta III Pull - 4 fronty 1/2

DE Aussenseite A  
PL Korpus A  
EN Outer face A  
IT Lato esterno A  
ES Lateral exterior A

DE Beschlagseite B  
PL Korpus B  
EN Fitting side B  
IT Lato ferramenta B  
ES Lado del herraje B

DE Falttüre Folding Concepta III 25 Pull  
PL Folding Concepta III 25 drzwi zewnętrzne  
EN Folding Concepta III 25 Pull folding door  
IT Porta a libro Folding Concepta III 25 Pull  
ES Puerta plegable Folding Concepta III 25 Pull

DE Falttüre Folding Concepta III 20 Pull  
PL Folding Concepta III 20 drzwi zewnętrzne  
EN Folding Concepta III 20 Pull folding door  
IT Porta a libro Folding Concepta III 20 Pull  
ES Puerta plegable Folding Concepta III 20 Pull

DE Drehtüre Folding Concepta III 25 Pull  
PL Folding Concepta III 25 drzwi wewnętrzne  
EN Folding Concepta III 25 Pull pivot door  
IT Porta girevole Folding Concepta III 25 Pull  
ES Puerta giratoria Folding Concepta III 25 Pull

DE Drehtüre Folding Concepta III 20  
PL Folding Concepta 20 drzwi wewnętrzne  
EN Folding Concepta III 20 pivot door  
IT Porta girevole Folding Concepta III 20  
ES Puerta giratoria Folding Concepta III 20

DETAIL G 2:1

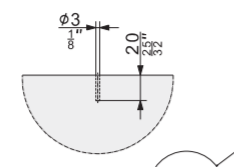

DETAIL D 2:1

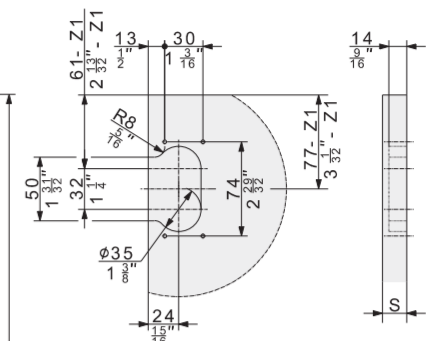

DETAIL E 2:1

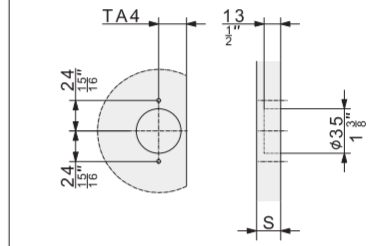

Z5	TA4
2 mm (3/16")	22.5 mm (7/8")
3 mm (1/8")	22 mm (7/8")
4 mm (5/16")	21.5 mm (7/8")
5 mm (3/16")	21 mm (7/8")

DETAIL F 2:1

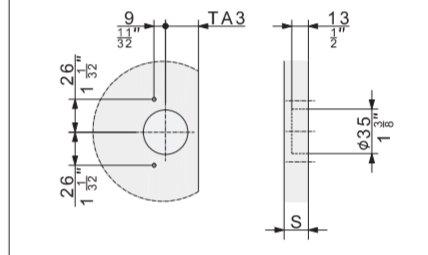

Z3	TA3
2 mm (3/16")	29 mm (1 1/8")
3 mm (1/8")	28 mm (1 1/8")
4 mm (5/16")	27 mm (1 1/8")
5 mm (3/16")	26 mm (1 1/8")

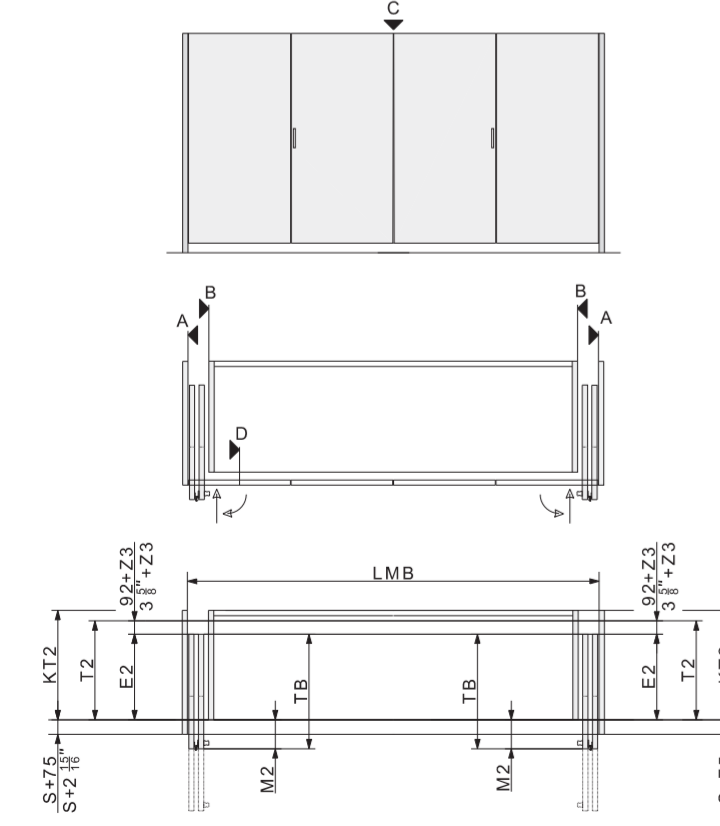
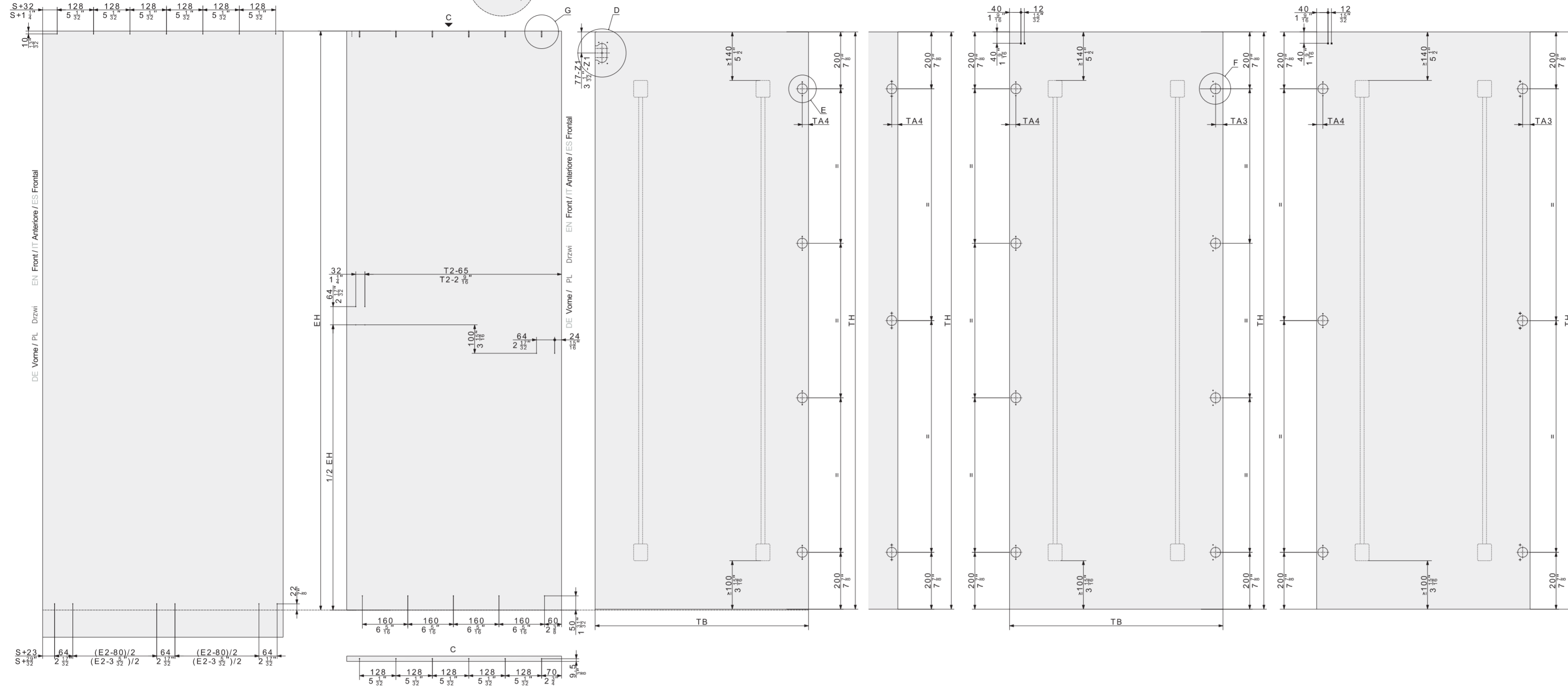

	mm
T2	TB + 92 + Z3 - M2
E2	TB - M2
KT2	± T2
M2	± S + 75
M2	± TB - 390

	mm
S	18 - 26
T2	± 344
TB	440 - 750
TH (III 20)	1200 - 2200
TH (III 25)	1900 - 2700
Z1	0 - 6
Z2	0 - 6
Z3	2 - 5
Z4	2 - 5
Z5	2 - 5

DE Schrankdeckel  
PL Pokrywa szafki  
EN Cabinet lid  
IT Coperchio del mobile  
ES Tapa del armario

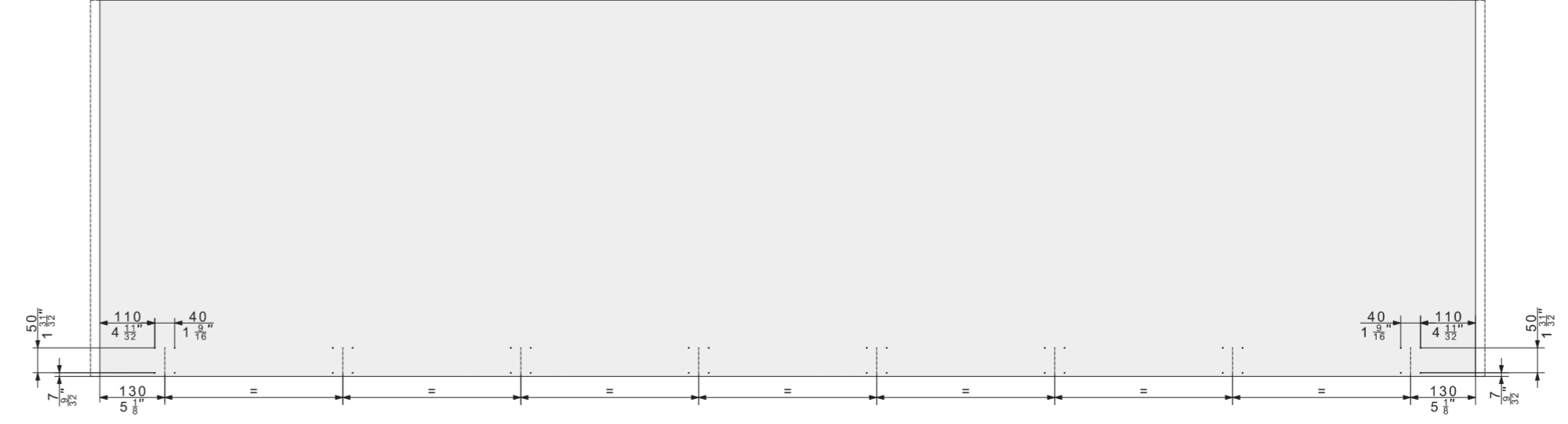

DE Abkürzungen / PL Legenda EN Abbreviations / IT Abbreviazioni / ES Abreviaturas

DE	PL	EN	IT	ES
E2	Głębokość wsunięcia	Slide-in depth	Profondità di inserimento	Profundidad de introducción
EH	Wysokość montażu	Installation height	Altezza d'incasso	Altura de montaje
KT2	Głębokość korpusu	Cabinet depth	Profondità mobile	Profundidad del mueble
LMB	Szerokość w świetle zabudowy	Inside clearance	Larghezza luce	Ancho interior
M2	Miejsce na uchwyty	Door projection over cabinet	Sporgenza anta sopra il mobile	Solape de la puerta sobre el cuerpo
S	Grubość drzwi	Door thickness	Spessore anta	Grosor de la puerta
T2	Głębokość montażowa	Hardware depth	Profondità ferramenta	Profundidad del herraje
TA	Odległość od środka puszk	Axis-centre distance of concealed hinge	Distanza scatola asse	Distanza de la cazoleta
TB	Szerokość drzwi	Door width	Larghezza anta	Ancho de puerta
TH	Wysokość drzwi	Door height	Altezza anta	Altura de puerta
Z	Luz międzyramien	Air gap	Traferro d'aria	Espacio libre

# Hawa Folding Concepta III Pull - 4 fronty 2/2