

# NOVA PRO SCALA H250

Wymiary montażowe / Mounting instructions / Notice de montage / Istruzioni di montaggio / Instrucciones de montaje

113691 - 01/2018

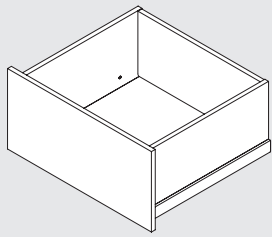

**Wymiary montażowe** Installation dimensions / Cotes de montage / Misure di montaggio / Medidas de montaje

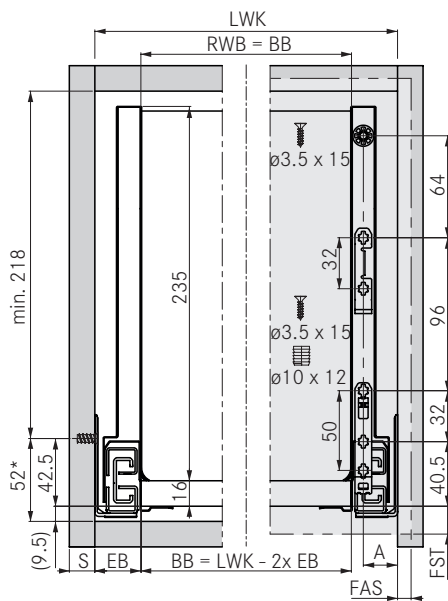

FB

HRW

**Wymiary docięcia** / Cutting dimensions / Cotes de découpe / Misure di sezionatura / Medidas de corte

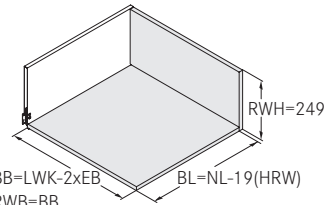
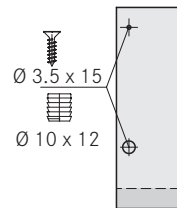

S	16/19	18
EB	29	29
A	21.5	21.5



**Instrukcja montażu** / Installed height of slide / Hauteur de montage coulisse / Altezza di montaggio guida / Altura instalada de guía

52\*: min. 49.5 mm  
min. 58 mm (Tipmatic Soft-close)

**Pozycje montażowe do pełnego wysuwu** / Fixing positions for full extension drawer slides / Positions de fixation pour coulisse à sortie totale / Posizioni di fissaggio per estrazione totale / Posiciones de fijación para guía de extracción completa

**Szuflada wewnętrzna** Inset drawer / Tiroir intérieur / Ripiano estraibile interno / Cacerolero interior

● Ø 6 x 13 mm

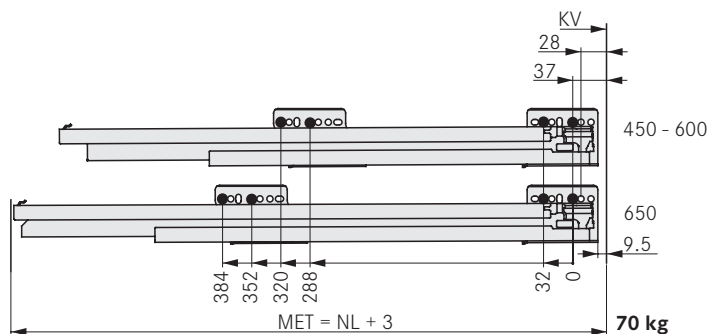
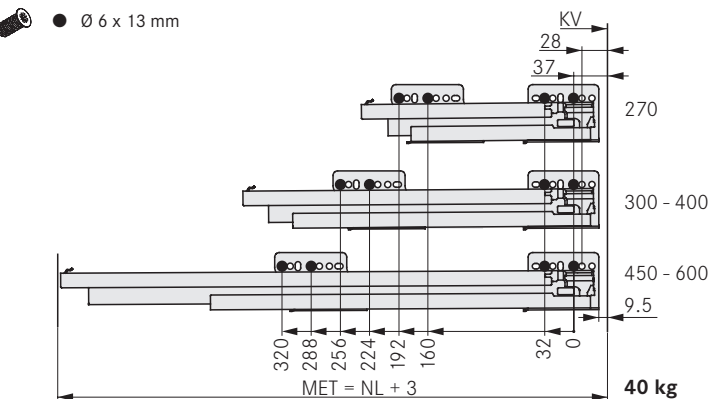

● Ø 6 x 13 mm

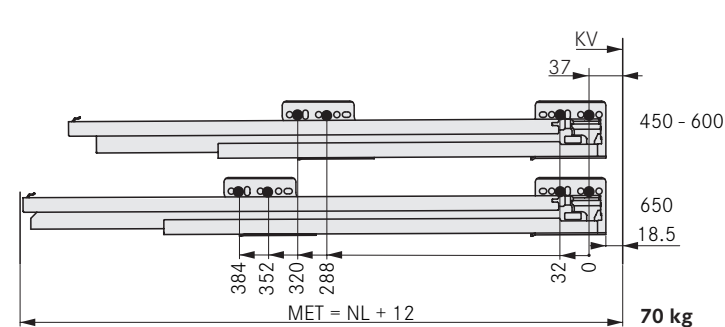
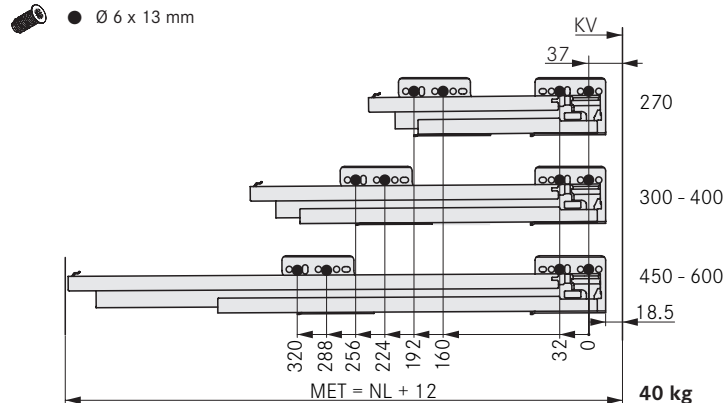

BB Szerokość dna / Bottom panel width / Largeur du fond / Larghezza fondo / Ancho del fondo

EB Szerokość instalacji / Installation width / Largeur de montage / Larghezza di montaggio / Ancho de montaje

FB Przednie mocowanie / Front holder / Fixation de façade / Fissaggio del frontale / Fijación de frentes

FAS Boczne nałożenie frontu / Front overlay, side / Recouvrement façade latérale / Base di appoggio frontale laterale / Cubrimiento del frente lateral

FST Dolne nałożenie frontu / Front overlay / Recouvrement façade bas / Sporgenza frontale / Saliente del frente

HRW Ścianka tylna / Wooden back panel / Panneau de bois / Legname parete posteriore / Traseras o madera

KV Krawędź przednia korpusu / Front edge of cabinet / Chant avant caisson / Fondo anteriore del mobile / Canto frontal del módulo

LWK Szerokość wewnętrzna korpusu / Inside cabinet width / Largeur intérieure caisson / Luce libera mobile / Ancho interior del módulo

MET Minimalna głębokość w świetle / Min. installation depth / Profondeur minimum de montage / Profondità minima d'incasso / Profundidad de montaje mínima

NL Długość prowadnicy / Nominal length / Longueur nominale / Lunghezza nominale / Longitud nominal

RWB Szerokość ścianki tylnej / Width of back panel / Largeur du dos / Larghezza schienale / Ancho de pared trasera

S Grubość frontu / Cabinet side wall / Panneau latéral du caisson / Parete laterale mobile / Lateral del módulo

# NOVA PRO SCALA H250

Regulacje/ Adjustment/Réglage/Sgancio del cassetto/Extracción del cajón

Wpinanie szuflady/ Inserting/Clipsage/Aggancio/Colgar

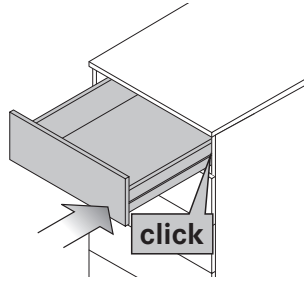
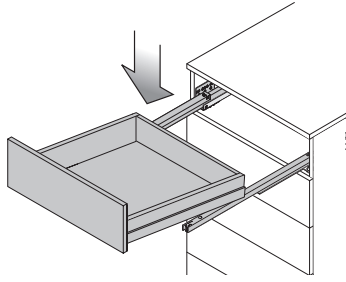

Wypinanie szuflady/ Removal/Décrochement/Sgancio/Descolgar

50%

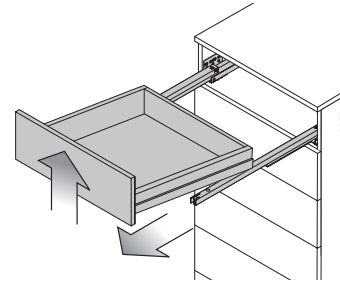
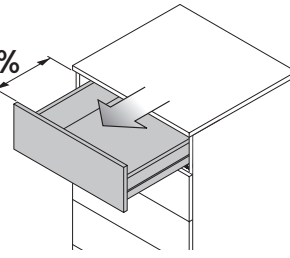

Regulacja wysokości/ Height adjustment/Réglage en hauteur/Regolazione dell'altezza/Regulación de altura

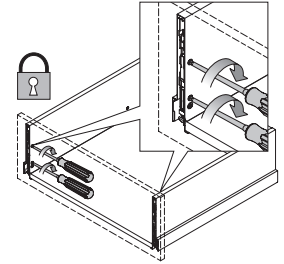
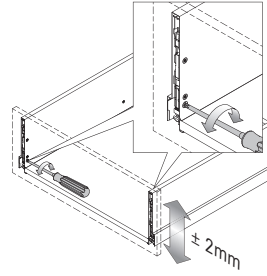
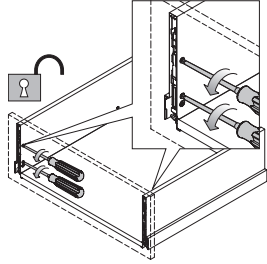
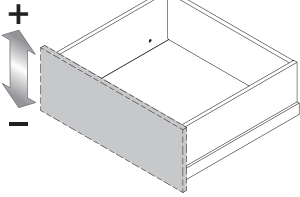

Regulacja boczna/ Side adjustment/Réglage latéral/Regolazione laterale/Regulación lateral

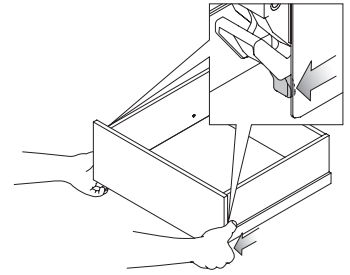
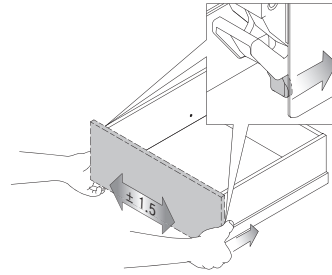
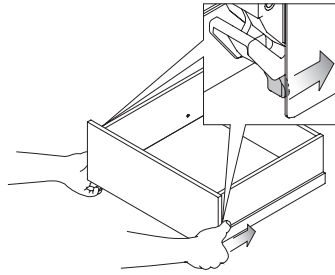
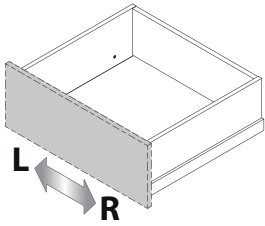

Regulacja nachylenia/ Tilt angle adjustment/Réglage de l'inclinaison/Regolazione dell'inclinazione/Regulación de inclinación

